

Remote handling connector development



Telemanipulator connector for JET project

- A remote handling connector can be operated at a distance (connected or disconnected) by a robot or manipulator.
- Telemanipulators for environments that are harsh or dangerous for humans. (Radioactive structure due to high energy neutrons)

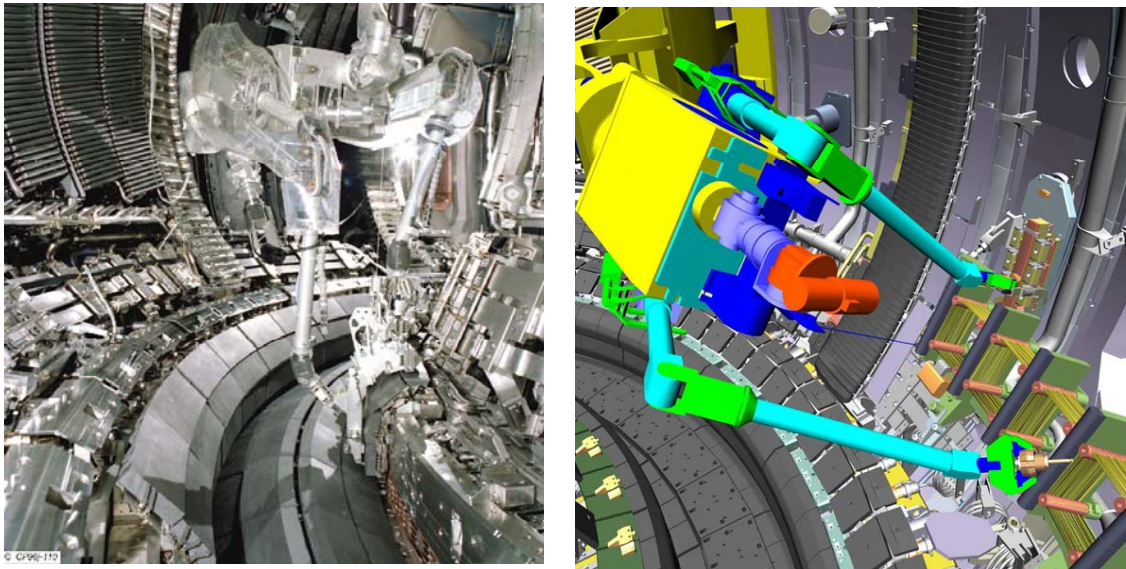
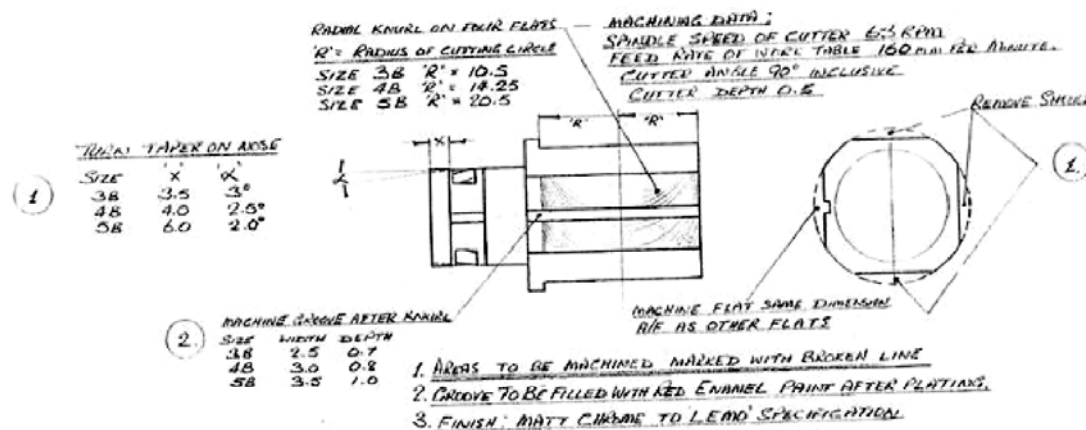

Photo: EFDA-JET

Development for JET (back in 1989)

- Connector with 4 flats (radial knurl for increased grip)
- Red visual indicator on the length of body
- Chamfer on connector nose to improve insertion
- No flange because operator needs to manipulate connector in-line



Remote connector interface

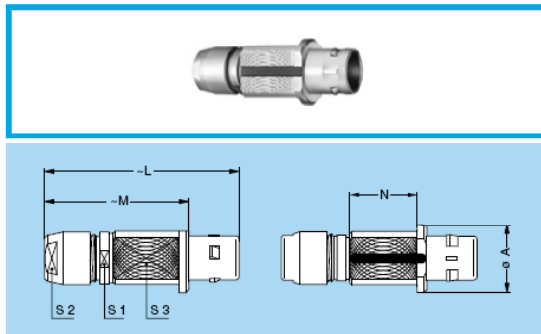

FIG Straight plug for remote handling, key (G) or keys (A...L and R), special alignment mark, knurled handling surface, cable collet

Reference		Dimensions (mm)						
Model	Series	A	L	M	N	S1	S2	S3
FIG	2B	20	49	37	17.5	13	12	15
FIG	3B	22	58	43	21.5	15	14	18
FIG	4B	30	75	57	28.5	21	20	25
FIG	5B	40	103	78	41.0	31	30	35

M1 Cable assembly (page 161)

PEEK insulator sustains up to 100MGy
 Outer shell in stainless steel 304L ensures radiation stability

Today's benefits

- JET started ordering LEMO connectors before 1988 and LEMO continued to supply reasonable quantities until 1999
- Customers today:
 - UKAEA -Atomic Energy Authority (UK)
 - National nuclear laboratory (UK)
 - Pyrosystemes (FR)
 - Camera systems (UK)
 - CEA (FR)
 - Telerobotic Manipulators (USA)
 - Institutt for energiteknikk (NO)
 - Mitsubishi Heavy Industries (JP)
 - Skoda (CZ)

For more information consult:

http://intra.lemo.ch/catalog/ROW/UK_english/N_Series_uk.pdf

http://intra.lemo.ch/catalog/USA/remote_handling.pdf

About LEMO

- Company
 - Approx. 1100 employees worldwide
 - 17 sales subsidiaries in Europe, USA, Middle East and Asia
 - Cable assembly, Fibre optic termination
- 4 production sites: St-Croix, Delémont, Ecublens (in Switzerland), Budapest (Hungary)
 - 99% production done in-house
- Connector products:
 - Push-Pull latching connectors, screw connectors
 - Unipole, multipole, high voltage, coaxial, triaxial, thermocouple, fibre optics
- Main markets in 2008
 - Test & Measurement (~22%)
 - Medical (~20%)

